

SLOTS	W		
	SDA50	SDA75	SDA100
1	1 5/16" (33)	1 9/16" (40)	1 13/16" (46)
2	2 9/16" (65)	3 1/16" (78)	3 9/16" (90)
3	3 13/16" (97)	4 9/16" (116)	5 5/16" (135)
4	5 1/16" (129)	6 1/16" (154)	7 1/16" (179)

NOMINAL LENGTH:

- 36" (914)
- 48" (1219)
- 60" (1524)

MODELS:

- SDA(I)50 - TO FIT SDS50 / SDR50
- SDA(I)75 - TO FIT SDS75 / SDR75
- SDA(I)100 - TO FIT SDS100 / SDR100

NOTES:

- ASSOCIATED SDS DIFFUSERS MUST BE SPECIFIED AND ORDERED AS SEPERATE ITEMS.
- INTENDED FOR USE IN T-BAR CEILING SYSTEMS
- NOT FOR USE WITH SDS TYPES 18, 19, 20, 21, 22
- NOT RECOMMENDED FOR PLASTER OR DRYWALL CEILINGS UNLESS ADJACENT ACCESS AVAILABLE.
- FACTORY TOLERANCE: ± 1/32" (1)

FINISH:

- MILL FINISH

MATERIAL:

- COATED STEEL

INSULATION OPTIONS (MODEL SDAI):

- CF - INTERNAL COATED FIBERGLASS INSULATION
- FF - INTERNAL FIBER FREE FOAM INSULATION

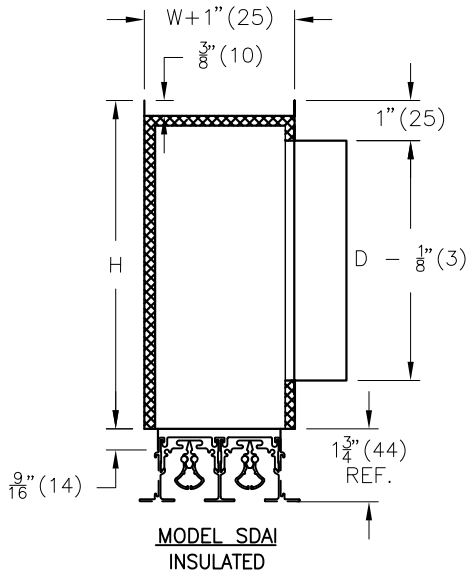

ALL METRIC DIMENSIONS () ARE SOFT CONVERTED. IMPERIAL DIMENSIONS ARE CONVERTED TO METRIC AND ROUNDED TO THE NEAREST MILLIMETER.

PROJECT:		PRICE®	
ENGINEER:			
CUSTOMER:		235055	TYPE 14 DIFFUSER INLET ASSY
SUBMITTAL DATE:	SPEC. SYMBOL:	2016/08/18	REV C

MODEL	LENGTH	SLOTS	H	D						
				4"	5"	6"	7"	8"	10"	
SDA50	36"	1	5 ⁹ / ₁₆ " (141)	•						
		2	6 ⁹ / ₁₆ " (167)		•					
		3	7 ⁹ / ₁₆ " (192)			•				
		4	8 ⁹ / ₁₆ " (217)				•			
	48"	1	6 ⁹ / ₁₆ " (167)		•					
		2	7 ⁹ / ₁₆ " (192)			•				
		3	8 ⁹ / ₁₆ " (217)				•			
		4	9 ⁹ / ₁₆ " (243)					•		
	60"	1	6 ⁹ / ₁₆ " (167)		•					
		2	8 ⁹ / ₁₆ " (217)				•			
		3	9 ⁹ / ₁₆ " (243)					•		
		4	11 ⁹ / ₁₆ " (294)						•	
SDA75	36"	1	5 ⁹ / ₁₆ " (141)	•						
		2	7 ⁹ / ₁₆ " (192)			•				
		3	8 ⁹ / ₁₆ " (217)				•			
		4	9 ⁹ / ₁₆ " (243)					•		
	48"	1	6 ⁹ / ₁₆ " (167)		•					
		2	8 ⁹ / ₁₆ " (217)				•			
		3	9 ⁹ / ₁₆ " (243)					•		
		4	11 ⁹ / ₁₆ " (294)						•	
	60"	1	7 ⁹ / ₁₆ " (192)			•				
		2	9 ⁹ / ₁₆ " (243)					•		
		3	11 ⁹ / ₁₆ " (294)						•	
		4	11 ⁹ / ₁₆ " (294)							•
SDA100	36"	1	6 ⁹ / ₁₆ " (167)		•					
		2	7 ⁹ / ₁₆ " (192)			•				
		3	9 ⁹ / ₁₆ " (243)					•		
		4	9 ⁹ / ₁₆ " (243)						•	
	48"	1	6 ⁹ / ₁₆ " (167)		•					
		2	8 ⁹ / ₁₆ " (217)				•			
			9 ⁹ / ₁₆ " (243)					•		
		3	11 ⁹ / ₁₆ " (294)						•	
	60"	1	11 ⁹ / ₁₆ " (294)							•
		2	7 ⁹ / ₁₆ " (192)			•				
		3	9 ⁹ / ₁₆ " (243)					•		
		4	11 ⁹ / ₁₆ " (294)						•	
	9 ⁹ / ₁₆ " (243)						•			
	11 ⁹ / ₁₆ " (294)							•		

• = AVAILABLE ROUND INLET

ALL METRIC DIMENSIONS () ARE SOFT CONVERTED. IMPERIAL DIMENSIONS ARE CONVERTED TO METRIC AND ROUNDED TO THE NEAREST MILLIMETER.

PROJECT:		PRICE®	
ENGINEER:		<i>MJ</i>	SDA, SDAI TYPE 14 DIFFUSER INLET ASSY
CUSTOMER:		235055	
SUBMITTAL DATE:	SPEC. SYMBOL:	2016/08/18	